



Renewables Based Microgrids For Army Mission Resilience

2026/04/08



BLOOD & FIRE!



WE ARE THE ARMY'S HOME



COYOTE STRONG!



FHL – At a glance



- Total Force Training Center for U.S. military components and allied nations
- Over 165 thousand acres of diverse training land
- Suited for year-round training and large-scale joint exercises
- Over 300 sunny days per year, with little to no rain between March and December
- Mediterranean climate. Conducive for heat pumps and other energy efficient systems
- FHL Cantonment area = 1,078.60 acres
- 1,278,333 SQFT of Facilities

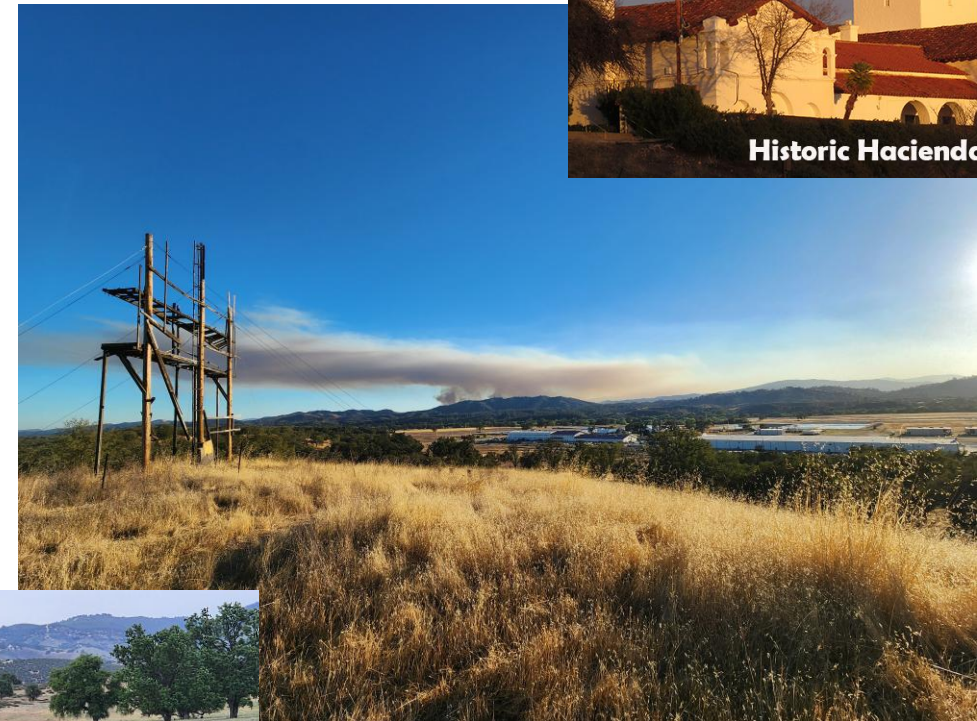

FHL – At a glance

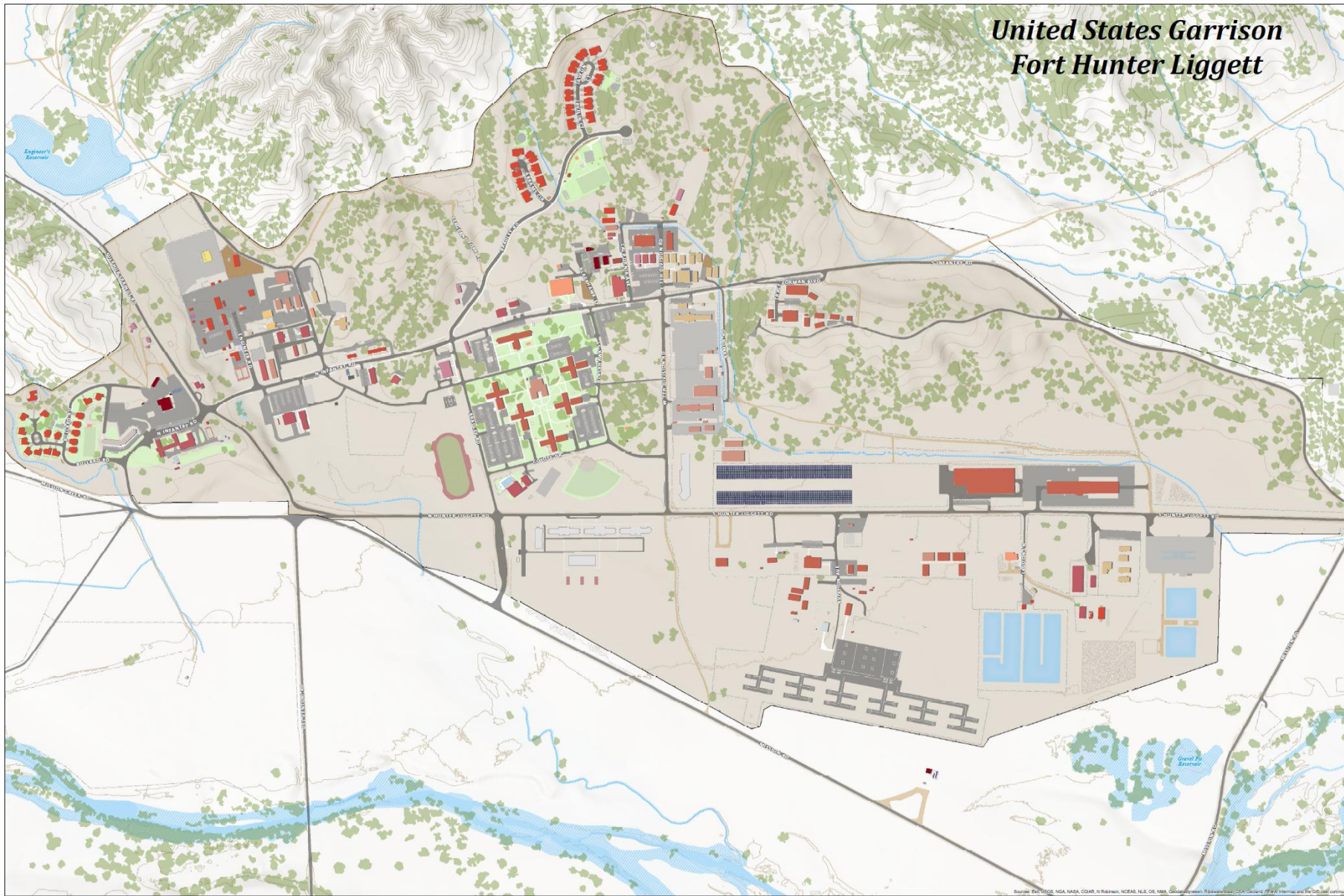

Why Build a Microgrid?



The Army's core purpose remains unchanged: *to deploy, fight, and win the nation's wars by providing ready, prompt, and sustained land dominance as part of the Joint Force.*

Risks to Continuity of Operations

FHL Challenges: FHL has longstanding challenges with electricity supplied by the utility

- FHL is remote and isolated and Utility's distribution lines are challenged
- Wildfires continue to impact the state and are getting more prevalent: Dolan Fire in Fall of 2020 burnt areas of FHL and could be seen from the Hacienda within the cantonment
- Public Safety Power Shutoffs: utility companies in California can institute pre-emptive blackouts in response to wildfire conditions
- Remote Location: Distance to propane/diesel resupply of generators, no natural gas lines
- Extreme Conditions: Atmospheric river, mudslide, seismic activity, wildfire

Solution: To mitigate these challenges, FHL began developing a long-term strategic plan for an installation-wide Solar & Battery powered microgrid to achieve mission resilience.



Over A Decade of FHL Resilience



2008 - 2015

- Pilot site for:
 - Net zero energy and waste
 - Army Reserve Integrated Strategic and Sustainability Planning process
- Completed net zero energy assessment and adopted net zero energy plan to reduce reliance on fossil fuels
- Installed solar photovoltaic panels (multiple phases) and battery storage (legacy)

2016 - 2020

- Awarded projects:
 - Heating, ventilation, and air conditioning (HVAC) controls optimization, I2C2 Integration, & HVAC features (Unitary heatpumps)
 - Secondary wastewater treatment facility
 - Ground source heat pumps for housing buildings
 - Cantonment microgrid
- Installation Energy and Water Plan completed
- Waste-to-energy demonstration
- Solid waste characterization study completed

2021 - 2030

Efficiency:

- Complete ongoing building controls and metering projects; expand advanced meters, and integrate all Facilities into the Installation control center
- Implement energy and water efficiency measures for critical buildings
- Initiate solid waste characterization recommendations

Resilient Infrastructure:

- Complete construction of the cantonment microgrid
- Study and size additional battery storage for the cantonment microgrid
- Award Energy Savings Performance Contract for potable well and ammo supply point microgrid (ongoing)
- Install emergency generator quick connects for Multipurpose Range Complex (ongoing)

Reduce Vulnerabilities:

- Complete design for water modernization project
- Repair water utility infrastructure
- Implement additional electrical overhead to underground projects
- Review third-party contracts for cybersecurity requirements “Hack-the-Grid”

FHL's success would not be possible without the support of our partnerships across the industry.

- California Energy Commission
- Pacific Gas and Electric
- Ameresco
- U.S. Army Office of Energy Initiatives
- Lawrence Berkeley National Laboratory
- Pacific Northwest National Laboratory





Integrated Installation Control Center

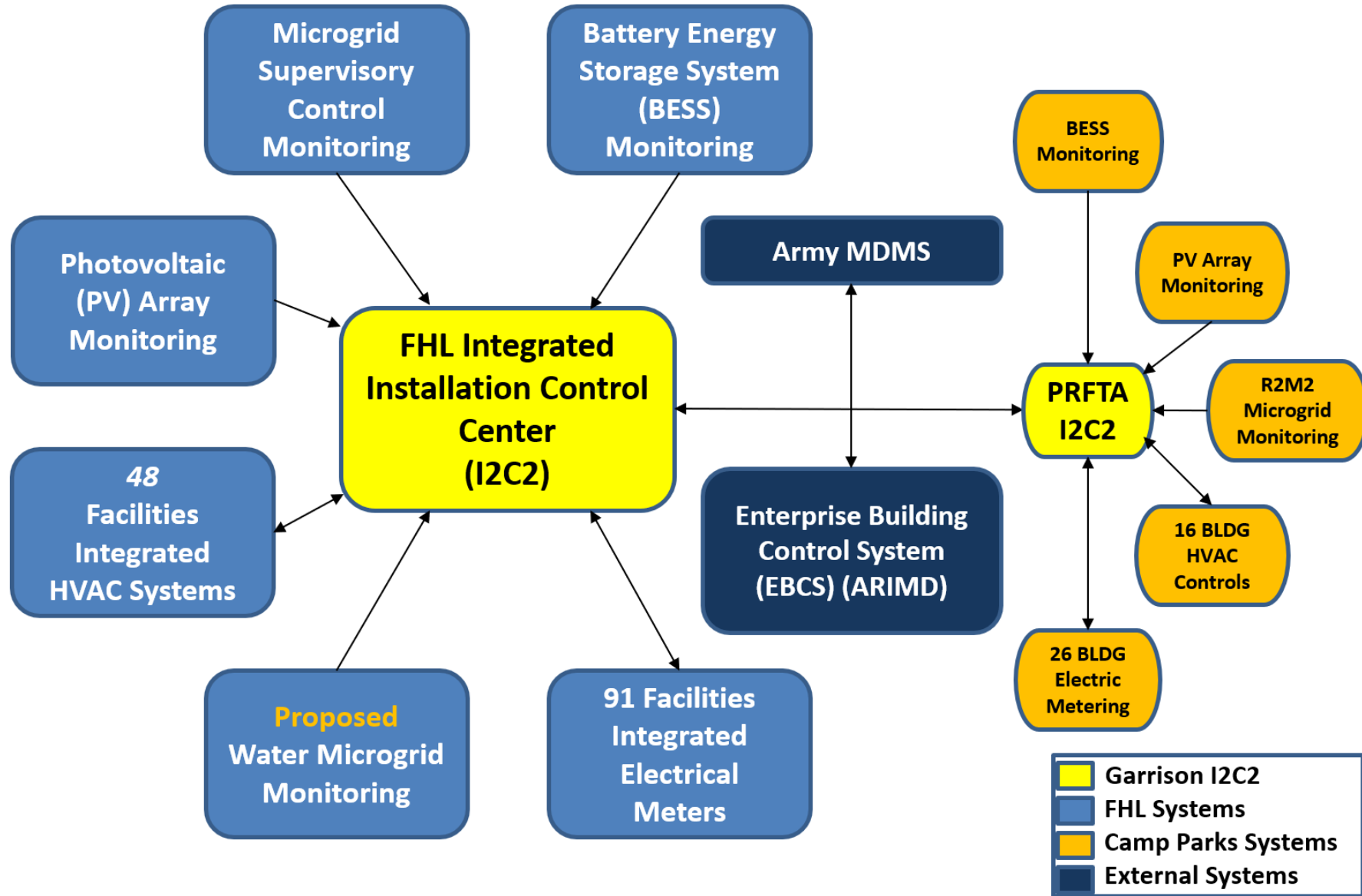

FHL – Microgrid At a glance



- In April 2019, a \$21M ERCIP project was awarded to Ameresco for construction of a campus wide microgrid

Including:

- 3.75MW of PV Generation
 - 2.15MW Truckport
 - 1.6MW Ground Mount
- 2.5MW/5MWh BESS
- 1 SCADA System to Rule Them All
- 13 Managed Distribution Switches
- 5 Barracks Buildings with low voltage switchgear controls

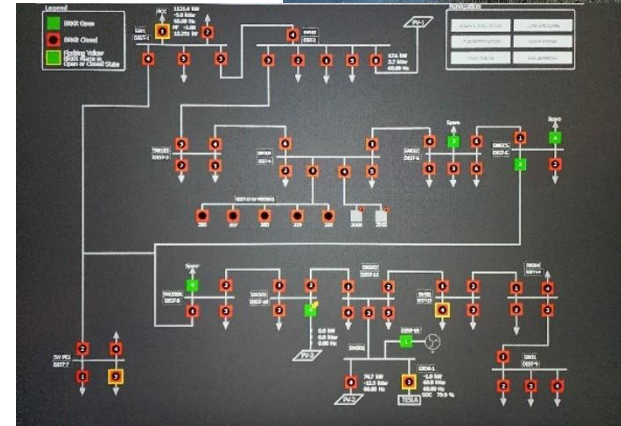
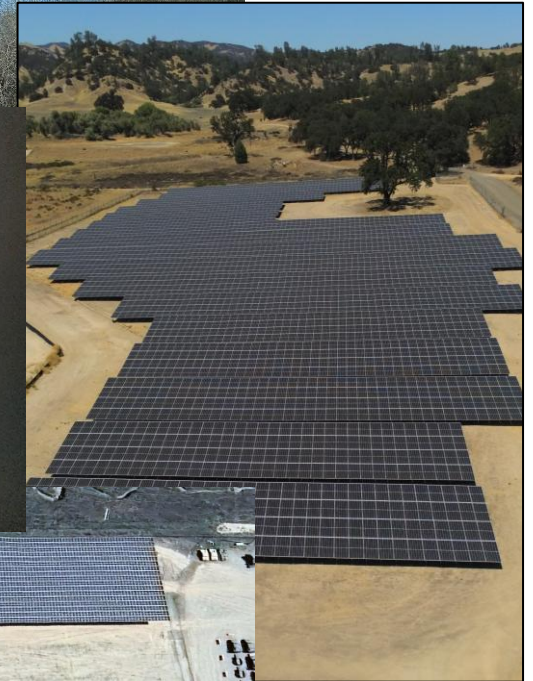



Microgrid Operation

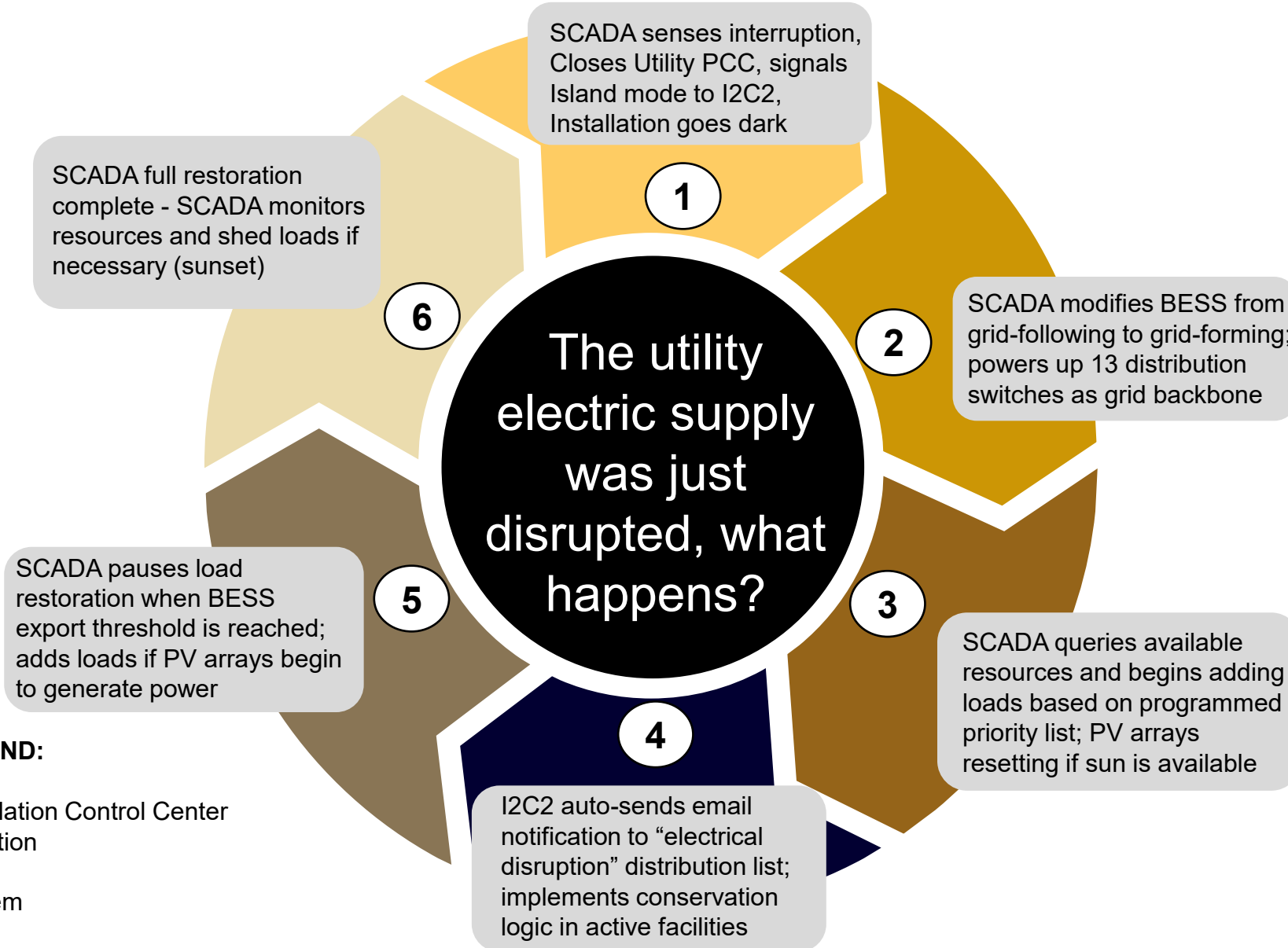

LEGEND:

- BESS= Batteries
- I2C2= Integrated Installation Control Center
- PCC= Point of Connection
- PV= Solar Array
- SCADA= Control System



Microgrid Monitoring

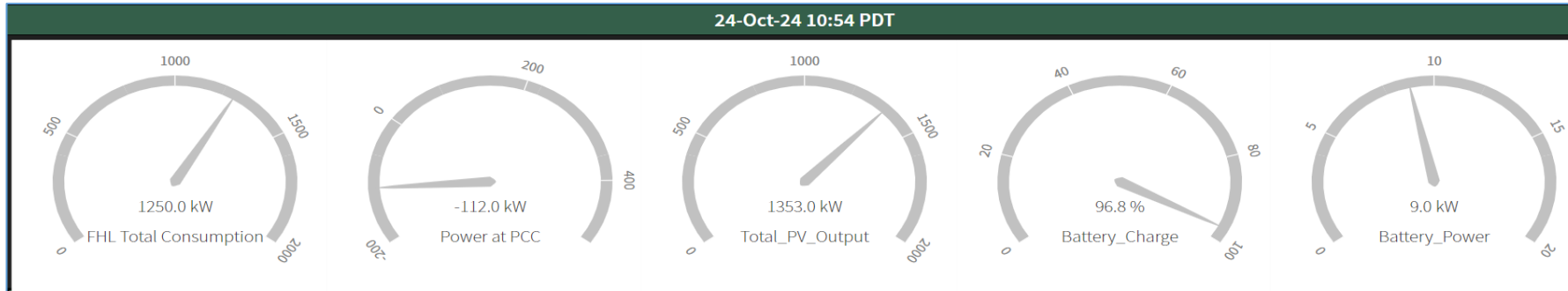

U.S. Army Garrison Fort Hunter Liggett Microgrid Resource Monitoring

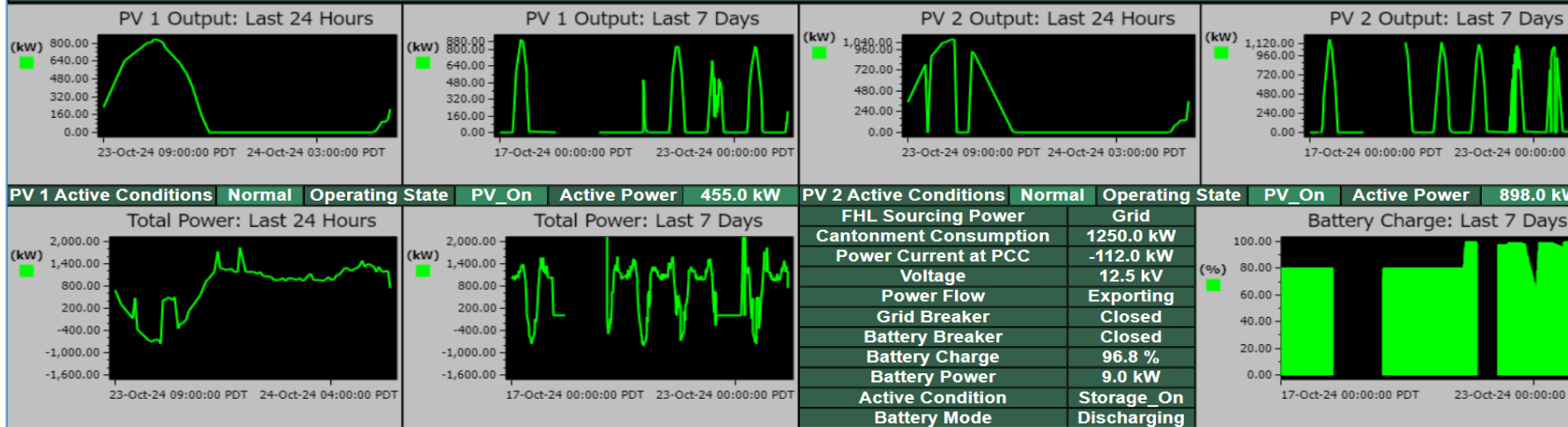

7-day Incident response January 2025

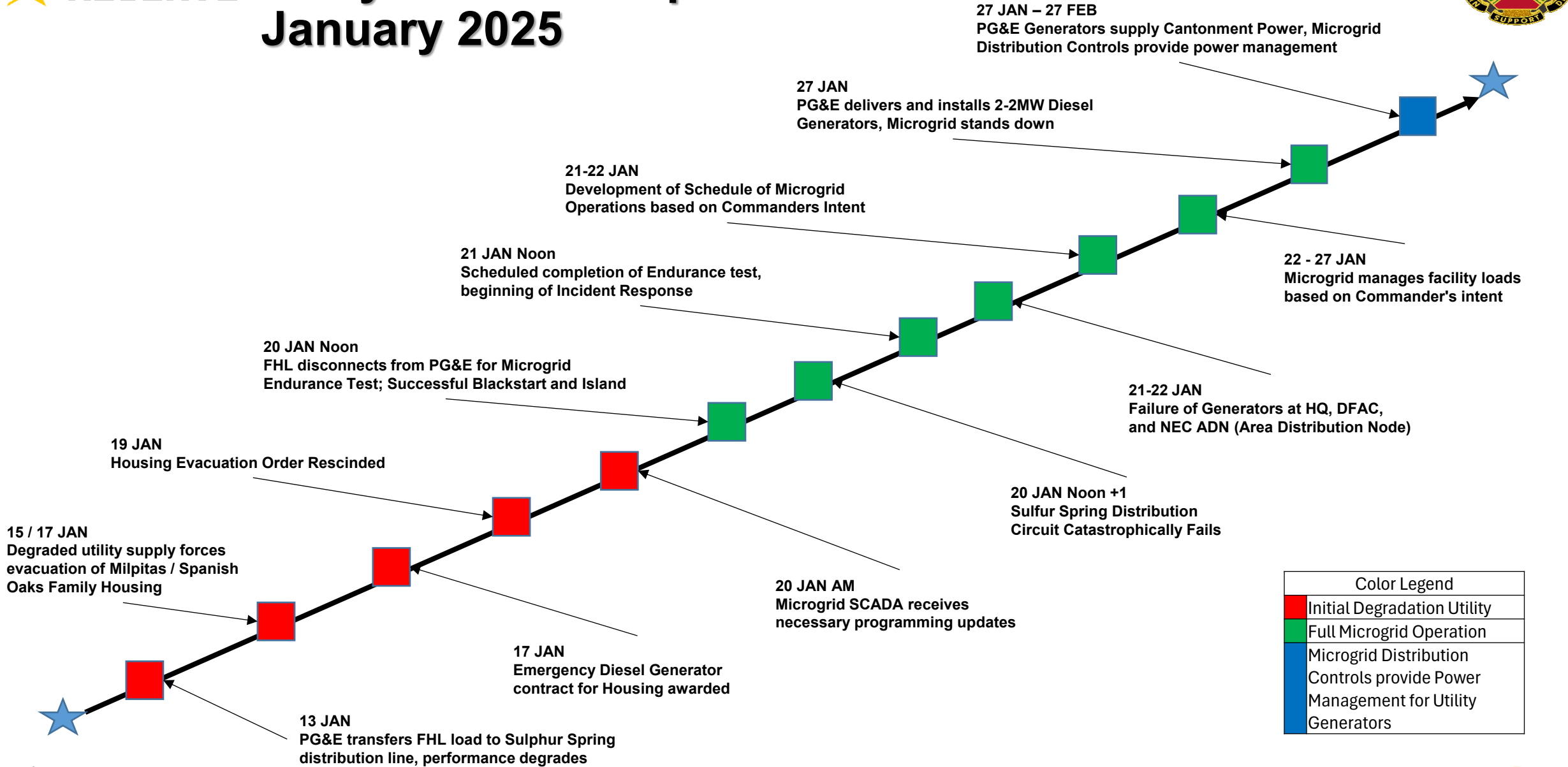

Color Legend	
	Initial Degradation Utility
	Full Microgrid Operation
	Microgrid Distribution Controls provide Power Management for Utility Generators



7-Day Incident Response



- Expanding the definition of critical mission infrastructure
 - Child Development Center
 - Gas Station
 - Dining Facility
 - PX/Post Office
 - Hotels
 - REC Center

- Maintenance and sustainment
 - ??

Schedule of Microgrid Operations

Load Priority	Load Name	Schedule	Comments
1A	Headquarters	Always on	
1B	Comms and ACP	Always on	
2A	DFAC	0500 - 1900	
2B	Child Development Center/CDC	0600 - 1800	
3	Barracks	1700 - 0800	
4	IHG - Hacienda	0500 - 0800 1700 - 2300	Shedable if resources low
5	Barracks	0500 - 0800 1900 - 2300	Shedable if resources low
5	Barracks	0500 - 0800 1900 - 2300	Shedable if resources low
6	Gas Station/Valero	1100 - 1700	
7	PX - Post Office	0900 - 1700	Shedable if resources low
8	Rec Center	1700 - 2100	
9	Fuel Point	as requested	
99	Gymnasium	can't turn it off if we wanted to	New Utility Manager is researching circuit



Conclusion

We must be able to accomplish our mission in a world defined by uncertain, adverse, and dynamic conditions. The fence line is now the front line. Army installations and enduring locations overseas must provide world-class training facilities, project power, surge the industrial base, sustain the force, and maintain command and control; this is only achievable with secure and resilient energy and water.

(Army Installation Energy and Water Strategic Plan, DEC 2020)



Questions?

